

# SUPPLEMENT TO INSTRUCTION MANUAL

P/N 238-44219-00

(Replaces pg. 2 in instruction manual.)

## CONGRATULATIONS!

You have just purchased one of the finest water heaters on the market today!

This installation, operation and instruction manual will explain in detail the installation and maintenance of your new Flammable Vapor Ignition Resistant Gas Water Heater. We strongly recommend that you contact a plumbing professional for the installation of this water heater.

We require that you carefully read this manual, as well as the enclosed warranty, and refer to it when questions arise. If you have any specific questions concerning your warranty, please consult the plumbing professional from whom your water heater was purchased. For your records we recommend that you write the model, serial number and installation date of your water heater in the maintenance section in the back of this manual.

This manual should be kept with the water heater.

### Special Flammable Vapor Ignition Resistant System:

This water heater is equipped with a Flammable Vapor Ignition Resistant System. In the event of improper usage or storage of gasoline or other flammable materials in the location where the water heater is installed, the technology will resist ignition of the flammable vapors outside the confines of the water heater.

The Flammable Vapor Ignition Resistant System features:

- Advanced Flame Arrestor Design.
- Intelligent Diagnostic Control to prevent burner/pilot operation with restricted airflow.
- Spark Igniter
- Sight Window to observe operation of pilot and burner.

**FOR YOUR SAFETY:** Activation of the Flammable Vapor Ignition Resistant System occurs when flammable vapors are drawn into the water heater and are combusted. If flammable vapors are detected:

- Do not try to light any appliance.
- Do not touch any electrical switch; Do not use any phone in your building.
- Leave the premises and immediately call the fire department from a neighbor's phone. Follow the fire department's instructions.

Once the flammable vapor has been evacuated, contact your plumbing professional or the manufacturer for further instructions. Replacement of a Flammable Vapor Ignition Resistant System equipped water heater due to a flammable vapor shutdown is not covered under the terms of the limited warranty.

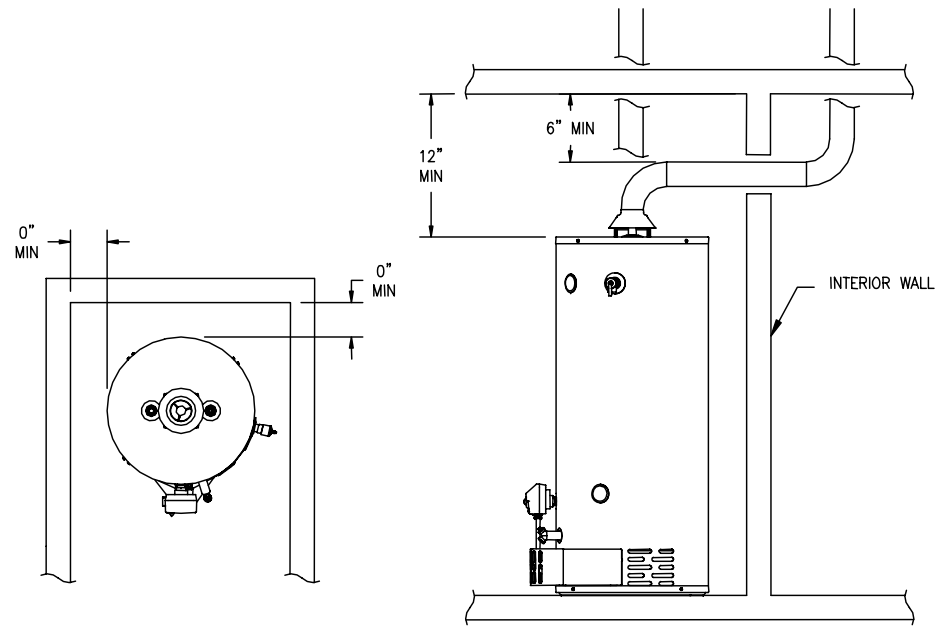
**MINIMUM CLEARANCES**  
(Replaces pg. 9 in instruction manual.)

**▲WARNING**

**Failure to adhere to these installation and operating instructions may create a hazard to life and property and will nullify the warranty.**

This installation shall allow access to the front of the water heater and adequate clearance shall be provided for servicing and operating this water heater. The water heater may be installed on either a combustible or non-combustible floor. If the water heater is to be installed directly on carpeting, it shall be installed on top of a metal or wood panel (or equivalent) extending beyond the full width and depth of the appliance by at least three (3) inches (7.6 cm) in any direction or, if the appliance is to be installed in an alcove or closet, the entire floor shall be covered by the panel. **If the rating plate or the label on the front of the heater specifies minimum clearances less than those listed in the below table, the water heater may be installed in accordance with the minimum clearances listed on the rating plate or the label on the front of the heater.**

If it is necessary to install this water heater in an alcove, use the clearances listed in Figure 1.



**Figure 1**

## Lighting and Shutdown Instructions (Replaces pg. 18 in instruction manual.)

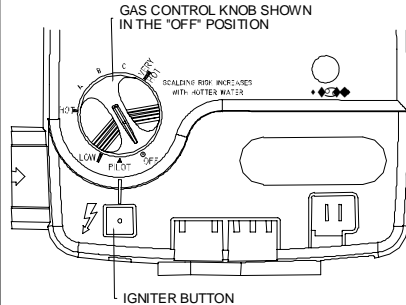
### FOR YOUR SAFETY READ BEFORE LIGHTING

**WARNING:** If you do not follow these instructions exactly, a fire or explosion may result causing property damage, personal injury or loss of life.

- A. This appliance has a pilot which is lit by a electric spark gas ignition system. Do not open the inner door and attempt to light the pilot by hand.
- B. BEFORE LIGHTING smell all around the appliance area for gas. Be sure to smell next to the floor because some gas is heavier than air and will settle on the floor.  
**WHAT TO DO IF YOU SMELL GAS.**
  - \* Do not try to light any appliance.
  - \* Do not touch any electric switch; do not use any phone in your building.
  - \* Immediately call your gas supplier from a neighbor's phone. Follow the gas supplier's instructions.
  - \* If you cannot reach your gas supplier, call the fire department.
- C. Use only your hand to push in or turn the gas control knob. Never use tools. If the knob will not push in or turn by hand, don't try to repair it, call a qualified service technician. Force or attempted repair may result in a fire or explosion.
- D. Do not use this appliance if any part has been under water. Immediately call a qualified service technician to inspect the appliance and to replace any part of the control system and any gas control which has been under water.

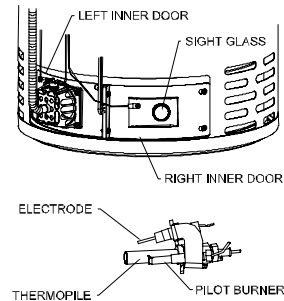
### LIGHTING INSTRUCTIONS

1. STOP! Read the safety information at the left on this label.
2. Set the gas control knob to the "OFF" position.



3. Wait five (5) minutes to clear out any gas. Then smell for gas, including near the floor. If you smell gas, STOP! Follow "B" in the safety information at the left on this label. If you don't smell gas, go to the next step.
4. Remove outer door.
5. Locate igniter button.
6. Look into sight glass window on right inner door to view pilot.
7. Turn the gas control knob clockwise to "PILOT" position.

8. Depress and hold in gas control knob. Immediately press igniter button until you hear a "click" sound, then release. Continue to hold down the gas control knob for about one (1) minute after the pilot is lit. Release the gas control knob it should pop back out. Check to see if the pilot is still lit through the sight glass. If the pilot goes out, repeat steps 2 through 8.
  - If gas control knob does not pop out when released, stop and immediately call your service technician or gas supplier.
  - If the pilot will not stay lit after several tries, turn the gas control knob to "OFF" and call your technician or gas supplier.

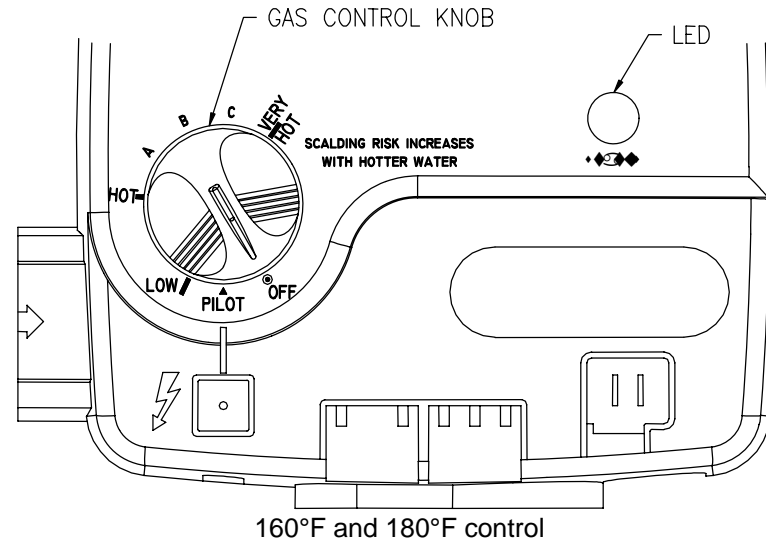


9. Replace outer door.
10. Turn gas control knob to desired setting.

### TO TURN OFF GAS TO APPLIANCE

1. Turn the gas control knob counterclockwise to the "OFF" position.

## THERMOSTAT ADJUSTMENT (Replaces pg. 19 in instruction manual.)



**Figure 2**

The gas control knob is set to the “OFF” position when shipped from the factory. **Remember that lower temperature settings are more energy efficient.** Adjust the temperature by turning the gas control knob. It is suggested that the starting point setting not exceed the approximately 120°F (48.9°C) or “Hot” setting on the thermostat.

### **⚠ DANGER**

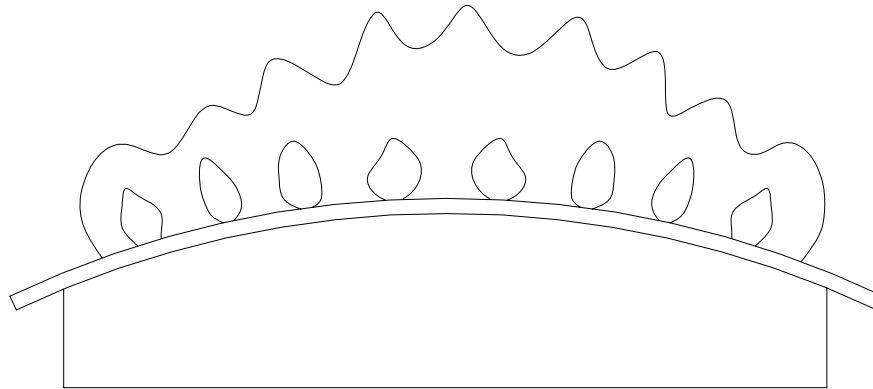
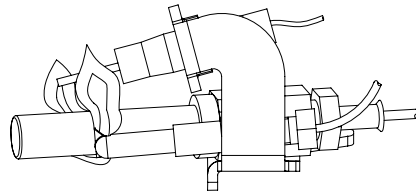
Hotter water increases the risk of scald injury. Scalding may occur within five (5) seconds at a temperature setting of 140°F (60°C). To protect against hot water injury, install an ASSE approved mixing valve in the water system. This valve will reduce point of discharge temperature by mixing cold and hot water in branch water lines. A licensed plumbing professional or local plumbing authority should be consulted.

**Note:** This water heater is equipped with an energy cut out device to prevent overheating. Should overheating occur or the gas supply fail to shut off, turn off the manual gas control valve to the appliance and call a qualified service technician.

**Note:** Whenever the water heater is filled with cold water, condensate will form on the cool tank surface and drops of water will fall on the hot burner and combustion chamber surfaces producing a “sizzling” noise. Condensation is normal and does not indicate a leak. It will disappear when the tank becomes heated.

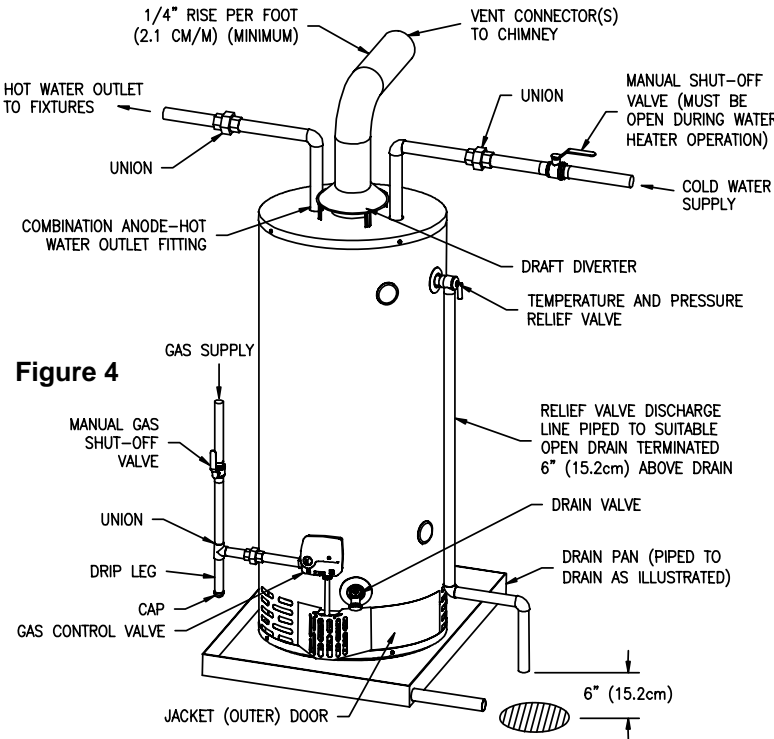
**BURNER FLAME CHECK**  
**(Replaces pg. 20 in instruction manual.)**

These models are equipped with self adjusting air mixture and do not have an adjustable air shutter. At periodic intervals, a visual check of the main burner and pilot flames should be made to determine if they are burning properly. The main burner flame should light smoothly from the pilot. The burner flame should be soft and undefined. After five minutes of burner operation the burner face should be glowing orange and emitting an orange flame.

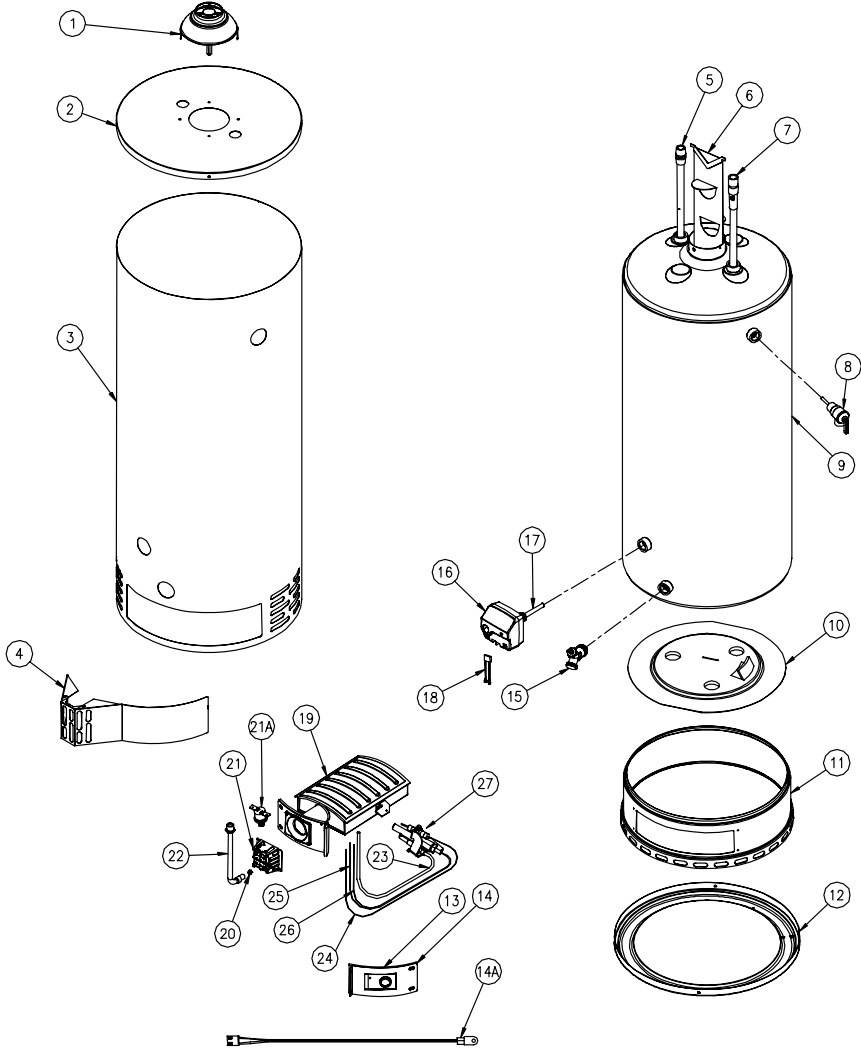


**Figure 3**

**INSTALLATION FOR POTABLE WATER**  
**(Replaces pg. 24 in instruction manual.)**



**PARTS LIST DRAWING**  
(Replaces pg. 25 in instruction manual.)



**PARTS LIST**  
**(Replaces pg. 26 in instruction manual.)**

PART NAME AND DESCRIPTION	
1. Draft Diverter	15. Drain Valve
2. Jacket Head Pan	16. Gas Valve
3. Jacket	17. Thermal Well
4. Outer Door	18. Wire Harness
5. Magnesium Anode–Hot Water Outlet	19. Radiant Burner
6. Flue Baffle Assembly	20. Orifice
7. Dip Tube–Cold Water Inlet	21. Manifold Mount
8. Temperature and Pressure Relief Valve	21a. High Temperature Limit Switch
9. Glass Lined Tank	22. Gas Feedline to Burner
10. Secondary-Air Restrictor Plate	23. Gas Feedline to Pilot
11. Combustion Chamber Assembly	24. Igniter Lead
12. Jacket Base Pan	25. Red Thermocouple Lead
13. Inner Door Gasket	26. White Thermocouple Lead
14. Inner Door Assembly	27. Pilot Assembly
14a. Resistance Temperature Detector	



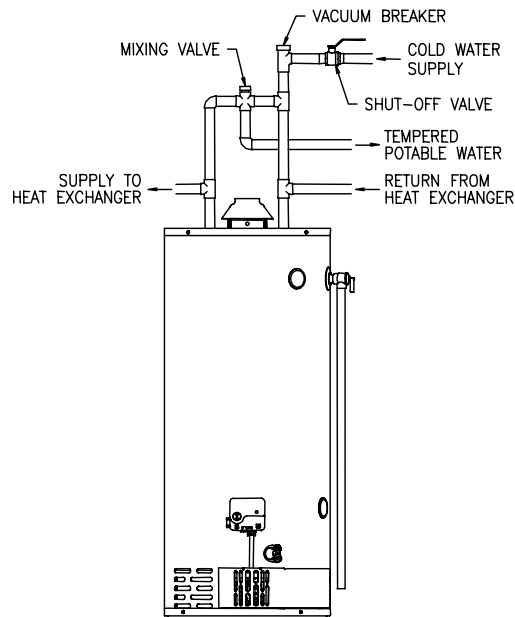
**THE FOLLOWING INSTRUCTIONS ARE FOR INSTALLATION OF:  
GAS WATER HEATERS SUITABLE FOR WATER (POTABLE)  
HEATING AND SPACE HEATING**

**(Replaces pg. 27 in instruction manual.)**

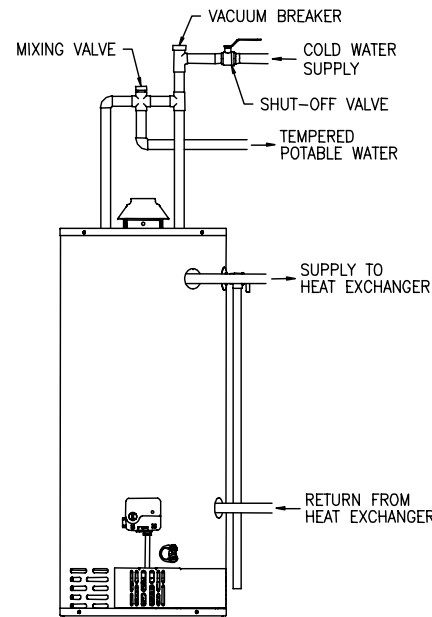
All piping components connected to this water heater for space heating applications must be suitable for use with potable water. In Massachusetts, space heating piping length **must not** exceed 50 feet.

1. Toxic chemicals, such as those used for boiler treatment, **must not** be introduced into potable water used for space heating.
2. This water heater **must not** be connected to an existing heating system or component(s) previously used with a non-potable water heating appliance.
3. When the system requires water for space heating at temperatures higher than required for other means, such as an ASSE approved mixing valve must be installed to temper the water for those uses in order to reduce the scald hazard potential.

Please refer to figure 5 and figure 6 for suggested piping arrangements.



**Figure 5**



**Figure 6**

**TROUBLESHOOTING**  
**(In addition to instruction manual.)**

LED Status	Control Status	Probable Cause
None (LED not on or flashing)	Gas valve is operating normally. Pilot flame may not be present. Check for pilot flame through sight glass and light if necessary.	<ol style="list-style-type: none"> <li>1. Gas valve is functioning normally</li> <li>2. Gas valve is not powered. Light pilot</li> </ol>
One flash and three second pause.	If set point knob is in "PILOT" position then pilot flame is detected. Turn set point knob to desired setting	Gas valve is powered and waiting for the set point knob to be turned to a water temperature setting.
LED on continuously.	Set point knob has been recently turned to the "OFF" position. Wait until LED goes out before attempting to relight	Set point knob was turned to "OFF" position.
Two flashes and three second pause.	Weak pilot flame detected. System will reset when pilot flame is sufficient.	<ol style="list-style-type: none"> <li>1. Unstable pilot.</li> <li>2. Pilot tube block or restricted.</li> </ol>
Three flashes and three second pause.	Insufficient water heating. System will reset.	<ol style="list-style-type: none"> <li>1. Thermowell sensor and chamber temperature sensor out of calibration.</li> <li>2. Possible short.</li> </ol>
Four flashes and three second pause.	Excessive tank temperature. System must be reset.	<ol style="list-style-type: none"> <li>1. Thermowell sensor out of calibration.</li> <li>2. Faulty gas valve.</li> </ol>
Five flashes and three second pause.	Thermostat well fault.	<ol style="list-style-type: none"> <li>1. Damage to the thermowell wire.</li> <li>2. Thermowell sensor resistance out of range.</li> <li>3. Replace thermowell.</li> <li>4. Verify control is not wet or physically damaged</li> <li>5. Turn set point knob to "OFF" position. Turn set point knob to "PILOT" position and light pilot.</li> <li>6. Replace gas valve if five flash error persists.</li> </ol>

**Troubleshooting continued-  
(In addition to instruction manual.)**

LED Status	Control Status	Probable Cause
Six flashes and three second pause.	Chamber temperature sensor out of specification. Possible short.	<ol style="list-style-type: none"> <li>1. Chamber temperature sensor out of calibration.</li> <li>2. Possible short.</li> </ol>
Seven flashes and three second pause.	Gas valve electronic fault detected.	<ol style="list-style-type: none"> <li>1. Verify control is not wet or physically damaged.</li> <li>2. Turn set point knob to "OFF" position. Turn set point knob to "PILOT" position and light pilot.</li> <li>3. Replace gas valve if seven flash error persists.</li> </ol>
Eight flashes and three second pause	False pilot flame present.	Pilot valve stuck in open position.
Ten flashes and three second pause	Insufficient combustion air detected. Reset system.	Insufficient combustion air.

## Notes